



Cambridge IGCSE™

CANDIDATE
NAME

CENTRE
NUMBER

--	--	--	--	--

CANDIDATE
NUMBER

--	--	--	--



PHYSICS

0625/52

Paper 5 Practical Test

February/March 2020

1 hour 15 minutes

You must answer on the question paper.

You will need: The materials and apparatus listed in the confidential instructions

INSTRUCTIONS

- Answer **all** questions.
- Use a black or dark blue pen. You may use an HB pencil for any diagrams or graphs.
- Write your name, centre number and candidate number in the boxes at the top of the page.
- Write your answer to each question in the space provided.
- Do **not** use an erasable pen or correction fluid.
- Do **not** write on any bar codes.
- You may use a calculator.
- You should show all your working and use appropriate units.

INFORMATION

- The total mark for this paper is 40.
- The number of marks for each question or part question is shown in brackets [].

For Examiner's Use	
1	
2	
3	
4	
Total	

This document has **12** pages. Blank pages are indicated.

1 In this experiment, you will determine the density of wood by two methods.

Carry out the following instructions, referring to Fig. 1.1.

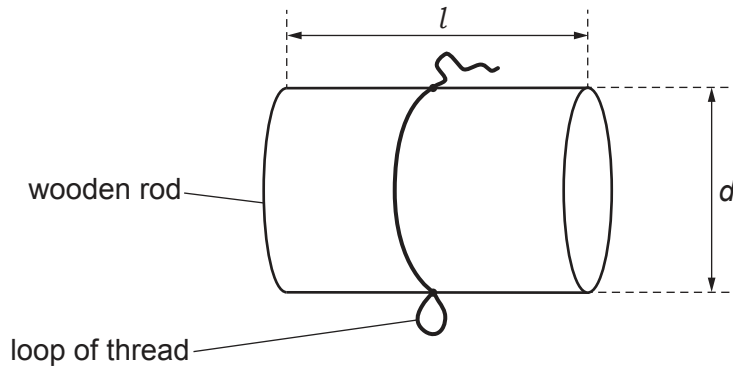

Fig. 1.1

Method 1

(a) (i) Use a ruler to measure the length l and the diameter d of the wooden rod you are using.

$l =$ cm

$d =$ cm
[2]

(ii) Suggest a more accurate method for measuring the diameter of the rod.

List any additional apparatus you would require and briefly describe how you would determine the diameter. You may draw a diagram if it helps to explain your answer.

You are **not** asked to carry out this method.

.....

 [2]

(b) Measure the mass m of the wooden rod using the balance provided.

$m =$ g [1]

- (c) Calculate a value ρ_1 for the density of the wooden rod. Use your values from (a)(i) and (b) and the equation $\rho_1 = \frac{4m}{\pi d^2 l}$. Include a suitable unit.

$$\rho_1 = \dots\dots\dots [2]$$

Method 2

- (d) (i) Pour approximately 150 cm³ of water into the measuring cylinder.

Record the reading V_1 of the water level in the measuring cylinder.

$$V_1 = \dots\dots\dots \text{ cm}^3$$

Gently lower the wooden rod into the water so that it floats freely as shown in Fig. 1.2.

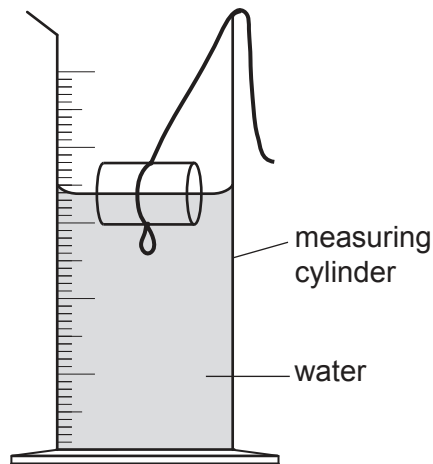

Fig. 1.2

Record the new reading V_2 of the water level in the measuring cylinder.

$$V_2 = \dots\dots\dots \text{ cm}^3 [1]$$

- (ii) On Fig. 1.2, **draw** an arrow on the left-hand side showing the correct line of sight for reading the volume of water in the measuring cylinder. [1]

(e)

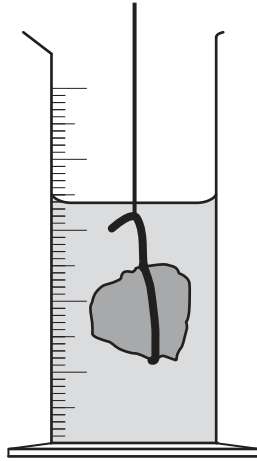

Fig. 1.3

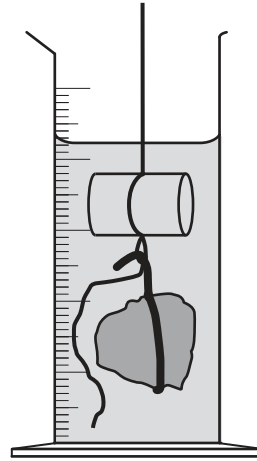

Fig. 1.4

Remove the rod from the measuring cylinder and lower the modelling clay into the water until it is completely submerged as shown in Fig. 1.3.

Record the new reading V_3 of the water level in the measuring cylinder.

$$V_3 = \dots\dots\dots \text{ cm}^3$$

Remove the modelling clay from the measuring cylinder.

Attach the rod to the modelling clay using the hook on the modelling clay and the loop of thread on the rod as shown in Fig. 1.4.

Lower the modelling clay and rod into the water until the rod is completely submerged.

Record the new reading V_4 of the water level in the measuring cylinder.

$$V_4 = \dots\dots\dots \text{ cm}^3$$

Calculate another value ρ_2 for the density of the wooden rod.

Use your values from (d) and (e) and the equation $\rho_2 = \frac{(V_2 - V_1)}{(V_4 - V_3)} \times k$ where $k = 1.0 \text{ g/cm}^3$.

$$\rho_2 = \dots\dots\dots [2]$$

[Total: 11]

2 In this experiment, you will investigate the cooling of hot water in a beaker.

Carry out the following instructions, referring to Fig. 2.1.

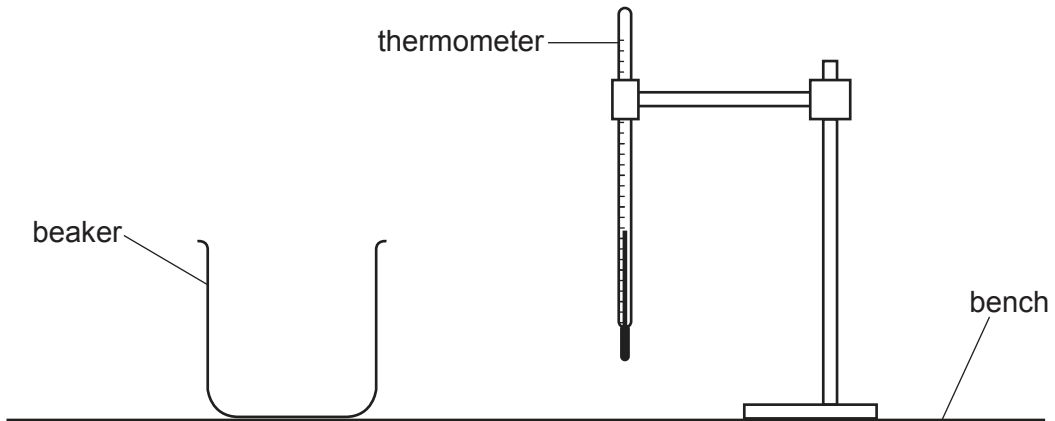

Fig. 2.1

(a) (i) Measure the room temperature θ_R shown on the thermometer.

$$\theta_R = \dots\dots\dots [1]$$

(ii) Pour 150 cm^3 of hot water into the beaker.
Place the thermometer in the water in the beaker.

In the first row of Table 2.1, record the temperature θ of the water at time $t = 0$ and immediately start the stop-clock.

In Table 2.1, record the temperature θ of the water at times $t = 30 \text{ s}$, 60 s , 90 s , 120 s , 150 s , 180 s , 210 s , 240 s and 270 s . [1]

(b) Complete the headings in Table 2.1. [1]

Table 2.1

$t/$	$\theta/$
0	
30	
60	
90	
120	
150	
180	
210	
240	
270	

- (c) (i) Calculate the average cooling rate x_1 during the first 90 s of the experiment. Use your readings from Table 2.1 and the equation

$$x_1 = \frac{\theta_0 - \theta_{90}}{T}$$

where $T = 90$ s and θ_0 and θ_{90} are the temperatures at $t = 0$ and $t = 90$ s. Include the unit for the cooling rate.

$$x_1 = \dots\dots\dots [1]$$

- (ii) Calculate the average cooling rate x_2 during the middle 90 s of the experiment. Use your readings from Table 2.1 and the equation

$$x_2 = \frac{\theta_{90} - \theta_{180}}{T}$$

where $T = 90$ s and θ_{90} and θ_{180} are the temperatures at $t = 90$ s and $t = 180$ s.

$$x_2 = \dots\dots\dots [1]$$

- (iii) Calculate the average cooling rate x_3 during the last 90 s of the experiment. Use your readings from Table 2.1 and the equation

$$x_3 = \frac{\theta_{180} - \theta_{270}}{T}$$

where $T = 90$ s and θ_{180} and θ_{270} are the temperatures at $t = 180$ s and $t = 270$ s.

$$x_3 = \dots\dots\dots [1]$$

- (d) (i) The temperature of the water falls as time passes. Use your results from (c) to describe the pattern of the rate of cooling of the water during the experiment. Justify your answer by reference to your results.

.....

 [1]

- (ii) Give an estimate of the probable final temperature θ_F of the water if left to cool for many hours.

$$\theta_F = \dots\dots\dots [1]$$

- (e) (i) A student in another school carries out a similar experiment. She starts with the hot water at a lower initial temperature. Suggest how her cooling rates are likely to compare with those calculated in (c). Use your results to explain your answer.

suggestion

.....

explanation

.....

.....

[2]

- (ii) State **one** variable, other than the initial temperature, which the student should control.

.....

..... [1]

[Total: 11]

- 3 In this experiment, you will investigate a power supply. The circuit has been set up for you.

Carry out the following instructions, referring to Fig. 3.1.

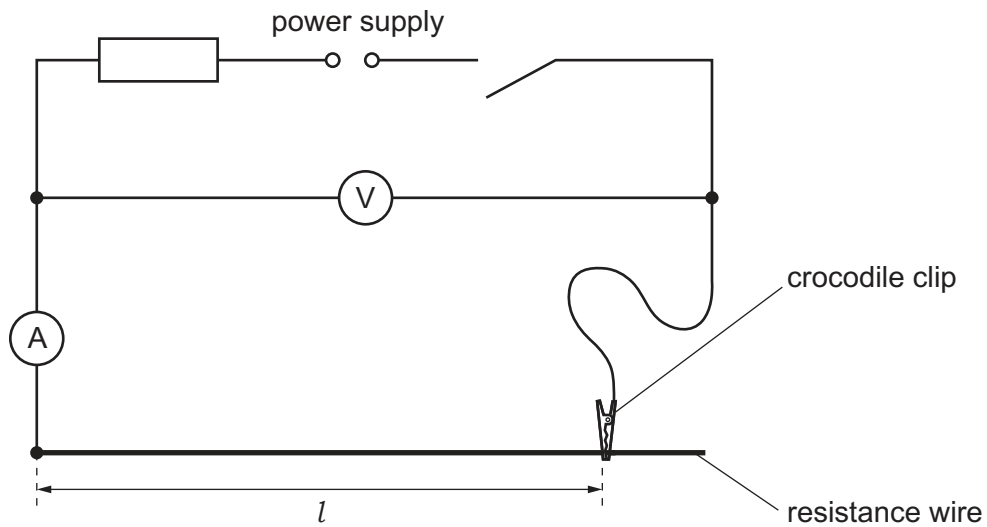

Fig. 3.1

- (a) Connect the crocodile clip to a length $l = 100.0$ cm of the resistance wire.

Switch on.

Measure the value of potential difference V_0 and current I_0 for the wire.

$$V_0 = \dots\dots\dots \text{ V}$$

$$I_0 = \dots\dots\dots \text{ A}$$

Switch off.

Calculate the resistance R_0 of 100.0 cm of the wire. Use your values of V_0 and I_0 and the

equation $R_0 = \frac{V_0}{I_0}$.

$$R_0 = \dots\dots\dots \Omega$$

[1]

(b) (i) Switch on.

Connect the crocodile clip to lengths $l = 70.0\text{ cm}$, 60.0 cm , 50.0 cm , 40.0 cm and 30.0 cm of the resistance wire in turn.

For each length l measure the current I in the circuit. Record your readings in Table 3.1. [1]

Switch off.

Table 3.1

l/cm	I/A	$\frac{1}{I} / \frac{1}{\text{A}}$
70.0		
60.0		
50.0		
40.0		
30.0		

(ii) Calculate, and record in Table 3.1, the value of $\frac{1}{I}$ for each length l of the wire. [1]

(c) Plot a graph of l/cm (y-axis) against $\frac{1}{I} / \frac{1}{\text{A}}$ (x-axis). You do **not** need to start your axes at the origin (0,0).

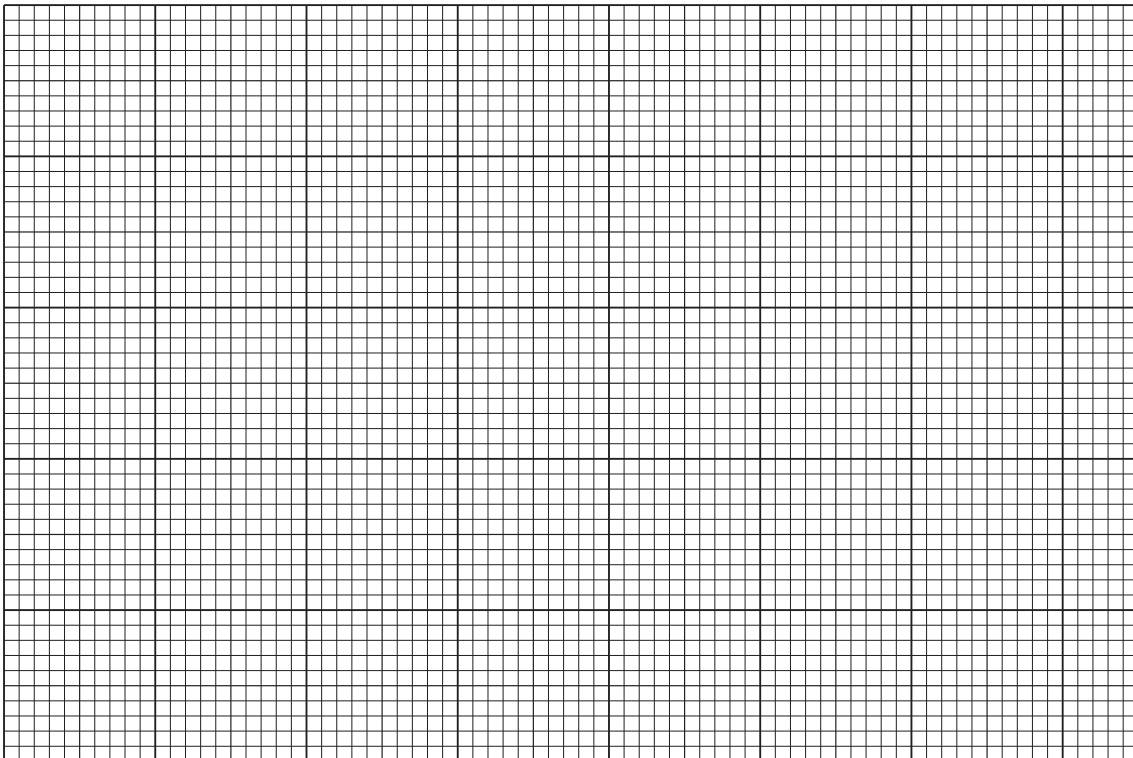

[4]

- (d) (i) Determine the gradient G of the graph. Show clearly on the graph how you obtained the necessary information.

$$G = \dots\dots\dots [1]$$

- (ii) Calculate the electromotive force (e.m.f.) E of the power supply. Use your value of R_0 from (a) and the equation $E = \frac{G \times R_0}{k}$, where $k = 100 \text{ cm}$.

$$E = \dots\dots\dots \text{ V } [1]$$

- (e) The ammeter in this circuit has a small resistance which affects the current. The effect of this resistance on the measured current I will be different for each measured length l of the resistance wire.

State and explain which length l will be most affected by the resistance of the ammeter.

statement

explanation

.....

[2]

[Total: 11]

4 A student investigates a wind turbine, which is an electrical generator driven by a propeller blade.

Plan an experiment which will enable him to investigate how the current in a resistor connected across the terminals of the turbine varies with the speed of the air flow through the turbine.

You are **not** required to carry out the experiment.

The apparatus available includes:

- a model wind turbine as shown in Fig. 4.1
- an electric fan to provide the moving air to turn the turbine
- a device for measuring air speed.

In your plan, you should:

- list any additional apparatus needed
- complete the wind turbine circuit diagram on Fig. 4.1
- state the key variables to be kept constant
- explain briefly how to carry out the experiment, including how the speed of the air flow is to be changed
- explain how to use the readings to reach a conclusion.

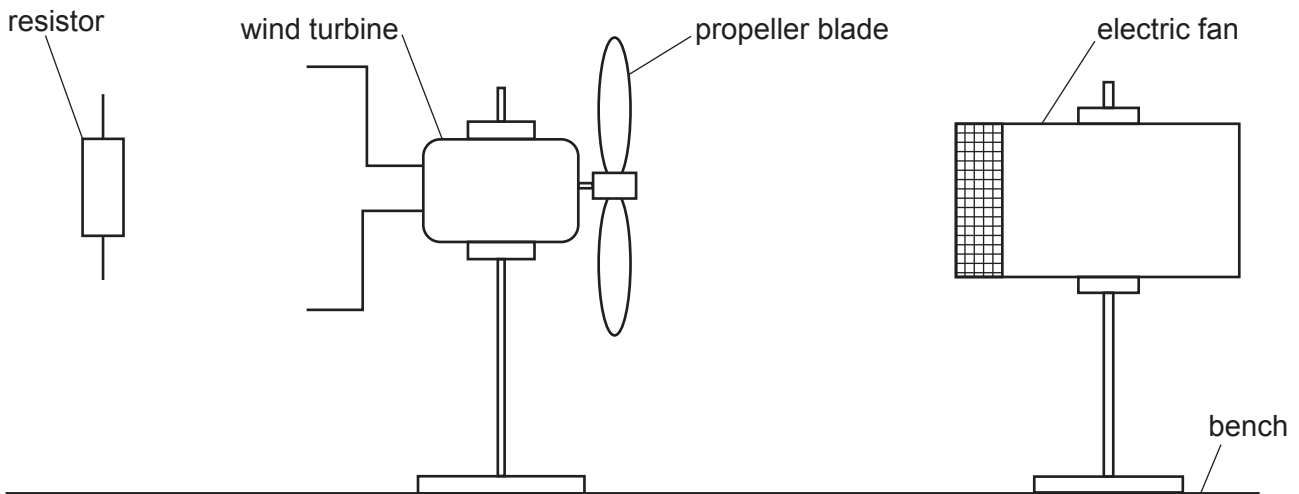

Fig. 4.1

.....

.....

.....

.....

.....

.....

.....

.....

